



# DTA100

Digital Transport Adapter



---

*Quick Start Guide*

## Before You Begin

### READ THIS FIRST

#### Connecting Your DTA100

##### 1. **Connect the DTA100 to your cable service.**

Connect the coaxial cable from your wall outlet to the connector on the back of the DTA100 labeled *Cable In*.

##### 2. **Connect the DTA100 to your A/V equipment.**

Refer to the illustrations in this guide to connect the DTA100 to your TV and other A/V components.

##### 3. **Turn on the DTA100.**

Plug the DTA100 power cord into the receptacle on the back of the unit. Plug the other end into a non-switched wall outlet. The DTA100 will turn on automatically.

##### 4. **(Optional) Connecting the Remote Extender.**

If you wish to place your DTA100 out of view, you can affix velcro squares to the two mounting squares on the bottom of the DTA100. Once in place, you can use the velcro squares to attach the DTA100 to the back of the TV or within the entertainment system.

When you place the DTA100 out of view, you must use the Remote Extender for the DTA100 to receive commands from the remote control. Insert the connector of the Remote Extender into the *IR IN* port and position the opposite end of the Remote Extender in view of the remote control (e.g. attached to the top of the TV).

##### 5. **Tune your TV to Channel 3 or 4**

Turn on your TV and ensure that it is tuned to either channel 3 or 4. On the back of the DTA100, ensure that the Ch 3/4 switch is set to the same channel as your TV.

##### 6. **Enjoy your new services!**

**Important:** If your TV screen is blank or you have no sound, you may have mixed the cable connections. After plugging a cable into the *Cable In* or *To TV* connector, be sure to plug the other end of the cable into the corresponding connector on your TV or other A/V component.

##### **Important handling and installation instructions**

- Install the terminal away from heat sources such as radiators, heat registers, and stoves. The air surrounding the terminal should not exceed 40°C (104 °F).
- Do not place the terminal in an enclosed area where the cooling vents are blocked or impede the flow of air through the ventilation openings.
- Position the unit with at least 3 inches of space on all sides.
- Place the terminal on a flat surface not prone to vibration or impact.
- Do not install the terminal in an area where condensation occurs.

## Overview

Congratulations on receiving a Motorola DTA100 Digital Transport Adapter.

### Connection Options

The DTA100 transport adapter supports the RF out (coaxial) video/audio connection. This connection supports Standard-Definition video and audio.

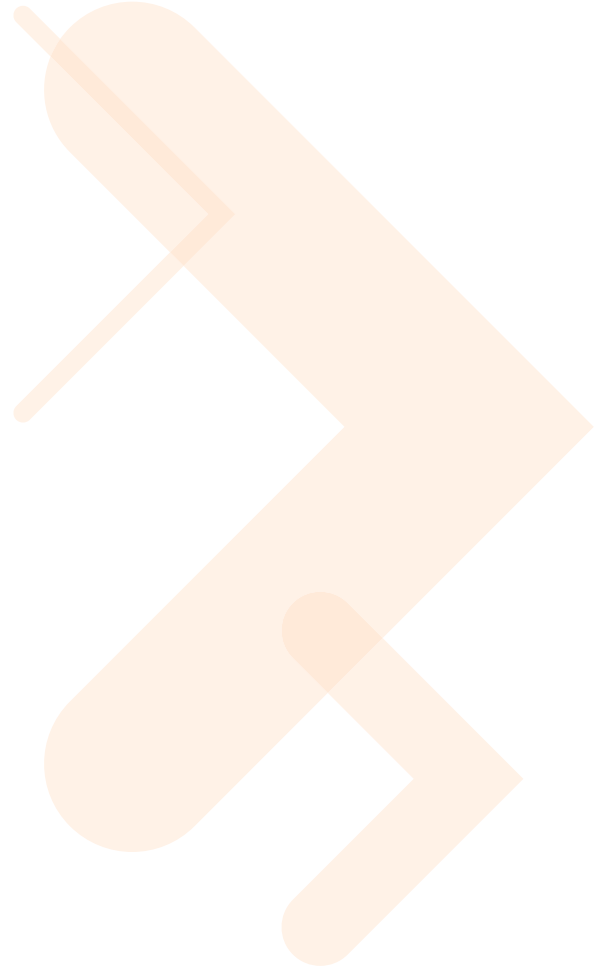

## Connecting Your Device

### Connecting an SDTV

1. Connect a coaxial cable from the cable wall outlet to the *Cable IN* connector on the DTA100.
2. Connect a coaxial cable to the *To TV* connector on the DTA100 and the *Cable / Antenna IN* on the TV.

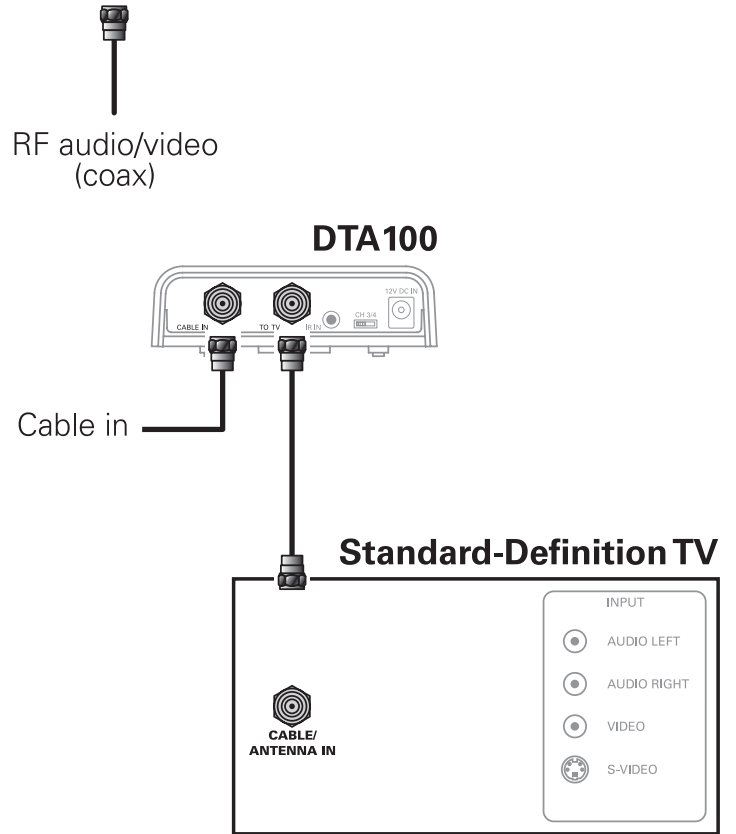

## Connecting Your Device

### Connecting an SDTV and VCR/DVD Recorder

1. Connect a coaxial cable from the cable wall outlet to the *Cable IN* connector on the DTA100.
2. Connect a coaxial cable to the *To TV* connector on the DTA100 and the *Cable / Antenna IN* on the VCR/DVD Recorder.
3. Connect a composite video cable from the *Video Out* connector on the VCR/DVD Recorder to the *Video In* connector on the TV and a stereo audio cable from the *Audio L / R Out* connectors on the VCR/DVD Recorder to the *Audio Left In* and *Audio Right In* connector on the TV.

or

Connect a coaxial cable to the *To TV* connector on the VCR/DVD Recorder to the *Cable / Antenna IN* connector on the TV.

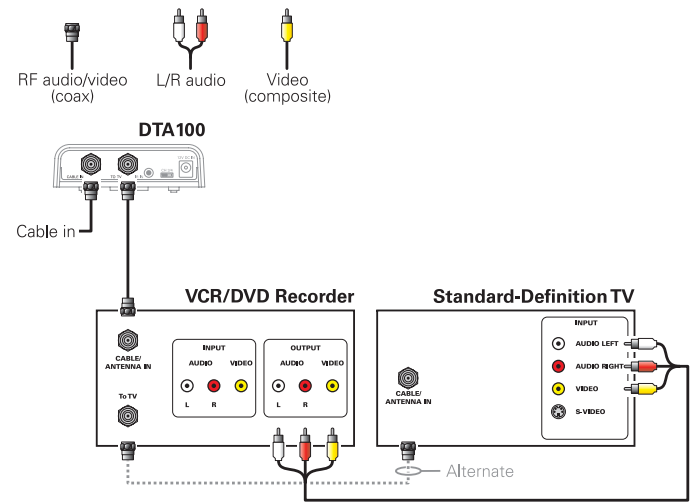

# Connecting Your Device

## Connecting an A/V Receiver, SDTV, and VCR / DVD Recorder

1. Connect a coaxial cable from the cable wall outlet to the *Cable IN* connector on the DTA100.
2. Connect a coaxial cable from the *To TV* connector on the DTA100 to the *Cable / Antenna IN* connector on the VCR/DVD Recorder.
3. Connect a composite video cable from the *Video OUT* connector on the VCR / DVD Recorder to the *VCR Video IN* connector on the A/V Receiver and a stereo audio cable from the *Audio L / R OUT* connector on the VCR / DVD Recorder to the *VCR Audio L / R IN* connector on the A/V Receiver.
4. Connect a composite video cable from the *TV / Monitor VIDEO OUT* connector on the A/V Receiver to the *Video IN* connector on the TV and a stereo audio cable from the *TV / Monitor AUDIO L / R OUT* connectors on the A/V Receiver to the *Audio Left* and *Audio Right* connectors on the TV.

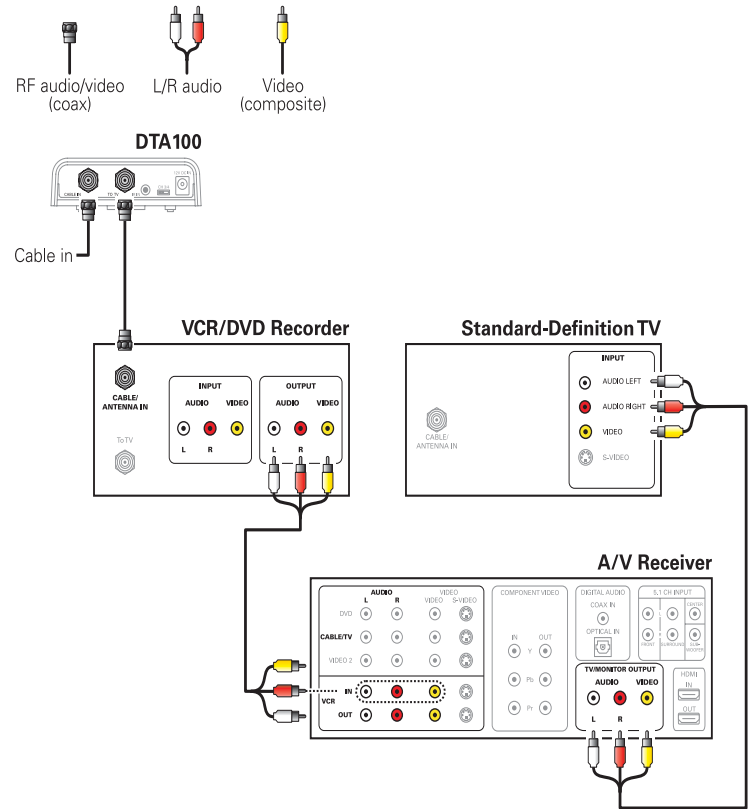

Before calling your service provider, review this troubleshooting guide. This information is to help you quickly solve a problem. If your problem still exists, contact your service provider.

Problem	Possible Solution
<b>The DTA100 will not power on</b>	<p>Verify whether the DTA100 is powered on by looking at the <i>POWER</i> icon on the front of the DTA100. If it is lit green, the DTA100 is powered on.</p> <ul style="list-style-type: none"><li>• If the DTA100 is connected to a switched outlet, verify the switch is turned on. It is recommended to use an unswitched outlet, if possible.</li><li>• Verify that the AC power cord of the external power supply is connected to the DTA100 and an AC outlet.</li><li>• Unplug the DTA100 from the AC outlet, and then plug it back in.</li></ul> <p>Verify that the remote control is in <i>Cable</i> mode, and turn the DTA100 on by pressing the <i>POWER</i> key.</p>
<b>The remote control does not work</b>	<p>Verify that the remote control is in <i>Cable</i> mode.</p> <p>Verify that there are no obstructions between the remote control and the DTA100. Aim the remote control directly at the DTA100 front panel or the Remote Extender, if connected, not the TV or VCR.</p> <p>The angle between the remote control and the DTA100 may be too large. Stand in front of the DTA100 and not too far to either side.</p> <p>Press and release operation keys one at a time, firmly and deliberately.</p> <p>Check the batteries in the remote control. Install new batteries if needed.</p>
<b>There is no video on the TV screen</b>	<p>Verify that the TV is powered on and set to the appropriate channel (3 or 4) for the DTA100.</p> <p>Verify that the DTA100 is powered on and tuned to an authorized cable channel.</p> <p>Verify that the coaxial cable between the DTA100 and the TV is firmly connected.</p> <p>Verify that the coaxial cable feed is firmly connected to the DTA100 and the wall jack.</p>
<b>There is no audio when viewing cable channels</b>	<p>Verify that the mute button on the remote control has not been pressed. Press <i>MUTE</i> on the remote control to restore sound.</p> <p>If the DTA100 audio output is connected to the TV, verify that the Mute button on the TV has not been pressed.</p>
<b>No closed captions display</b>	<p>Verify that closed captions are enabled on the TV.</p> <p><i>Note: Closed captioning may not be available on the current program.</i></p>



**MOTOROLA**

Motorola, Inc.  
www.motorola.com

MOTOROLA and the Stylized M Logo are registered in the U.S. Patent and Trademark Office. All other product or service names are the property of their registered owners.

© Motorola, Inc. 2008  
556788-001-a 11/08



This device is ENERGY STAR® qualified when connected to a digital video service. The Service Provider is responsible for completing the ENERGY STAR Partnership Agreement prior to deploying any Set-top device with an ENERGY STAR label, or claiming to provide ENERGY STAR qualified Set-top devices in advertising or promotional materials.

