



# QIP7100 P2

Hybrid QAM/IP High-definition Set-top



***Quick Start Guide***

## Introduction

Congratulations on receiving a Motorola QIP7100 Hybrid QAM/IP High-definition Set-top. This document will help you set up your Hybrid QAM/IP HD Set-top to quickly get it up and running.

### READ THIS FIRST

1. Determine if you are connecting to a:

---

**High-Definition TV or monitor**

Use the HDMI, component video (YPbPr), or IEEE-1394 outputs. No other video connection supports HDTV. If the TV has no HDMI input but does have a DVI input, connect a DVI-to-HDMI adapter or cable to the HDMI out connector on the QIP set-top instead of the IEEE-1394 connection, and the DVI-HDTV connector on your TV.

---

**Standard-Definition TV**

Connect the S-Video connector using an S-video cable, or connect the composite video connector using a composite (RCA phono) cable. If the TV only has a coaxial RF input, connect it to the QIP7000 series RF OUT connector.

---

2. Determine if you are connecting the audio to a home theater receiver or directly to the TV:

- For an HDMI or IEEE-1394 video connection, no additional audio connections are required.
- For a DVI video connection, additional audio connections are required.
- If the receiver or TV has a digital audio (S/PDIF) input, use the Optical Audio (S/PDIF) or Digital Audio (COAXIAL) outputs.
- Otherwise, use the baseband left and right audio outputs.

3. Locate the cabling diagram(s) that best match the configuration.

4. Connect the audio and video cables in a manner matching that diagram.

5. Determine if you are connecting to a data device. For installation details, refer to the instructions included with the data device.

6. Connect the Fios TV In terminal to the coaxial cable wall outlet.

7. Perform the operational check for the remote control.

8. Optimize the high-definition settings.

## Front Panel

The front panel controls provide functional navigation if the remote control is lost or is temporarily out of service. Certain functions, such as those requiring a numeric entry, require a remote control. Some connectors are not enabled and require the support of application software.

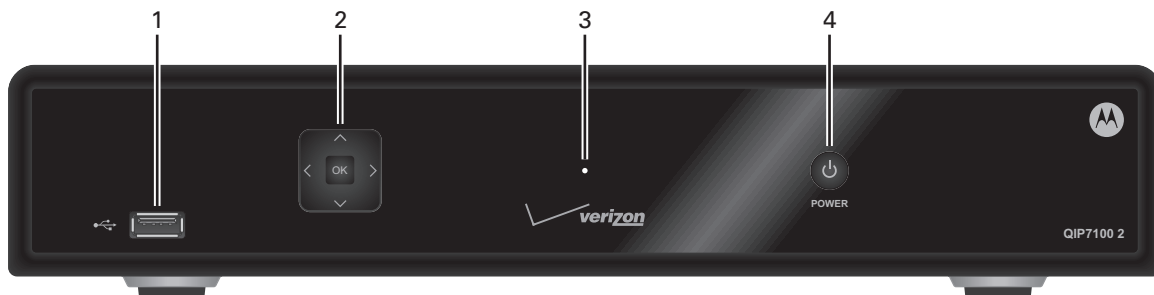

1	USB connector
2	Cursor — 4-way menu navigation
3	• — Startup Indicator
4	Power — Turns the set-top on and off (standby)

## Rear Panel

The rear panel contains a 3-prong power outlet; connectors for video, audio, and RF cabling; data output; and data interface connectors. Some connectors are not enabled and require the support of application software.

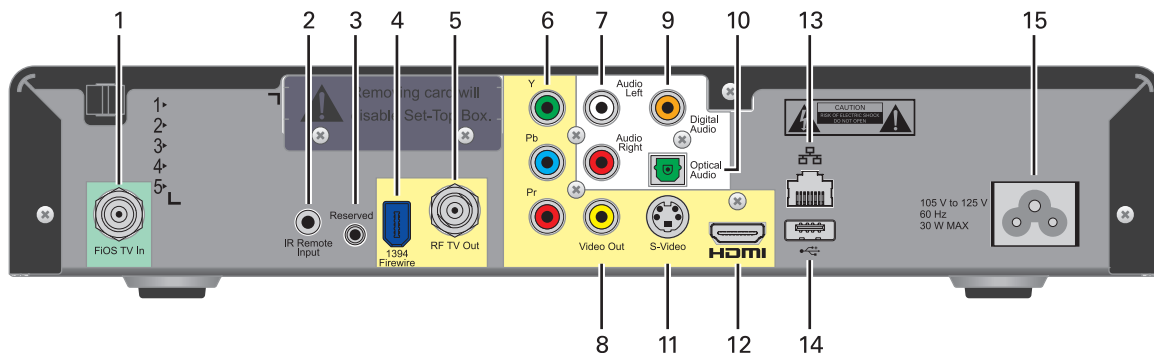

1	FiOS TV In — Connects to FiOS signal from your service provider
2	IR Remote Input — Connects to a remote control set-top accessory cable
3	Reserved – Service only
4	IEEE-1394 — Audio and video device connection
5	RF Out — Ch 3/4 modulated audio/video (SDTV) to TV or VCR
6	YPbPr — Component video output (HDTV)
7	Audio — Composite Audio L/R outputs
8	Video — Composite Video (SDTV) output
9	Digital Audio (Coaxial)* — Provides Dolby® Digital 5.1 audio or PCM output
10	Optical Audio (S/PDIF)* — Provides Dolby® Digital 5.1 audio or PCM output
11	S-Video — Connects to S-Video (SDTV) input of TV or VCR
12	HDMI — High-Definition TV (HDTV) connector
13	Ethernet* — Network connection
14	USB* 2.0 — High-Speed peripheral device connection
15	Power cord connector — 3-prong AC outlet

\*Feature is dependent upon application setting and availability in content

## Cabling to an HDTV for Video

For the best possible HDTV video quality:

1. If the TV has an HDMI input, connect it to the QIP7100 HDMI output. If the TV has a DVI input, you can connect it to the QIP7100 HDMI output using an HDMI-to-DVI converter cable or adapter.
2. If the TV has neither an HDMI nor a DVI input but has an IEEE-1394 input, connect it to the QIP7100's IEEE-1394 output. If you use IEEE-1394, on-screen graphics do not display.
3. Otherwise, use the component video (Y, Pb, and Pr) connectors.
4. A digital audio or L/R audio connection connection is required for sound with component video.

*Note: Be sure to match up each signal to the same connection on the TV. Otherwise, the colors will not appear correctly on your TV.*

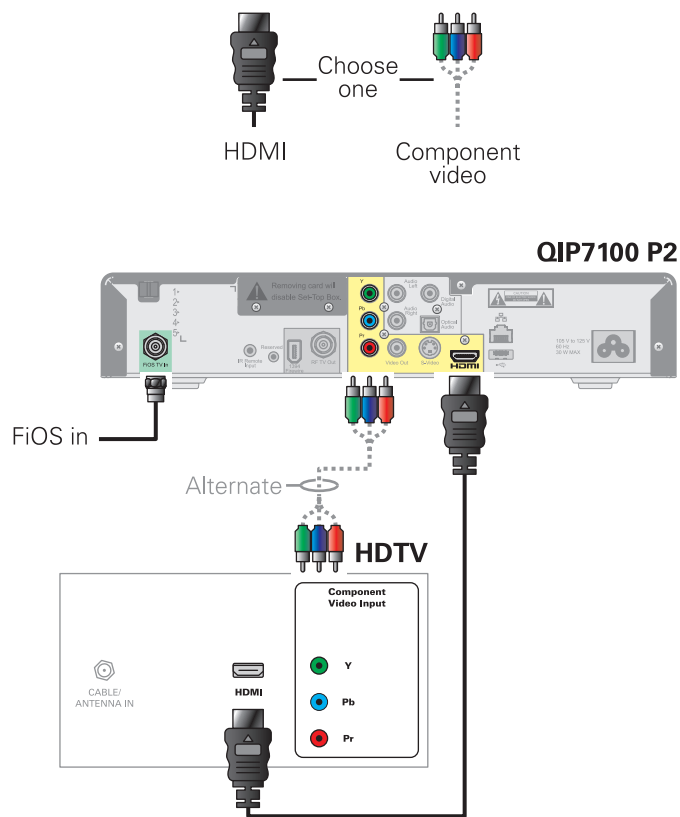

*Note: Because HDMI provides both video and audio output, no additional audio connections to the TV are required.*

## Cabling to an HDTV for Audio

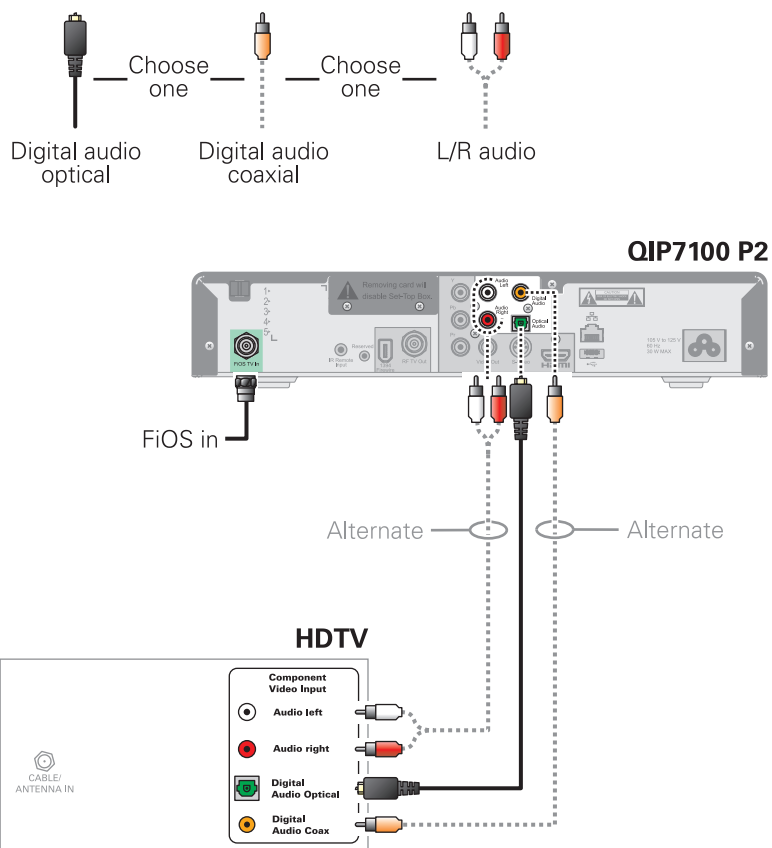

## Cabling to a High-Definition TV and an A/V Receiver for Video

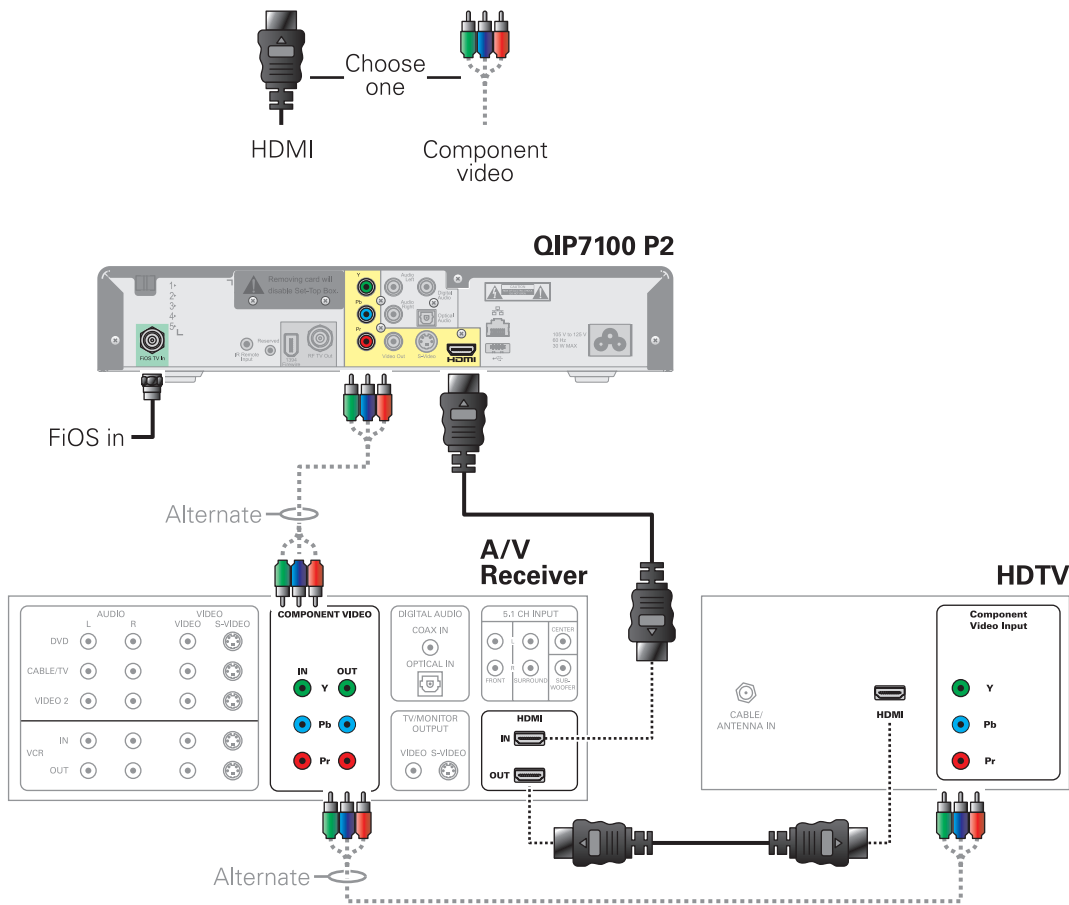

*Note: If the A/V receiver includes an HDMI input and output, the QIP7100's HDMI output can be connected directly to the A/V receiver's input and the A/V receiver's HDMI output directly to the TV. Because HDMI provides both video and audio output, no additional audio connections to the A/V Receiver and TV are required.*

## Cabling to a High-Definition TV and an A/V Receiver for Audio

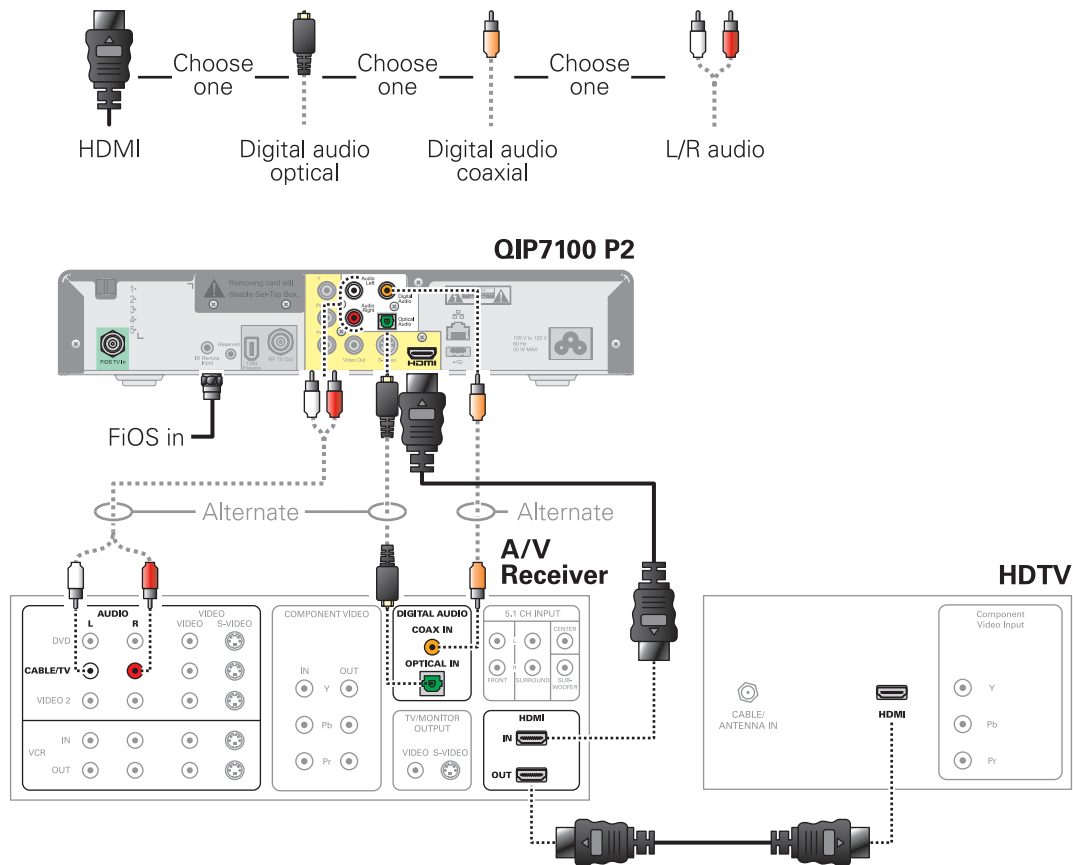

*Note: If the A/V receiver includes an HDMI input and output, the QIP7100's HDMI output can be connected directly to the A/V receiver's input and the A/V receiver's HDMI output directly to the TV. Because HDMI provides both video and audio output, no additional audio connections to the A/V Receiver and TV are required.*

*Note: If the receiver can check the baseband and digital audio (S/PDIF) ports for appropriate channels, connect both the baseband and digital audio connections. Otherwise, do not connect both the baseband left/right composite connections and the coaxial digital connection. The baseband connections are not necessary because the digital audio port provides a single audio interface for digital and analog channels.*

## Cabling to a Standard-Definition TV

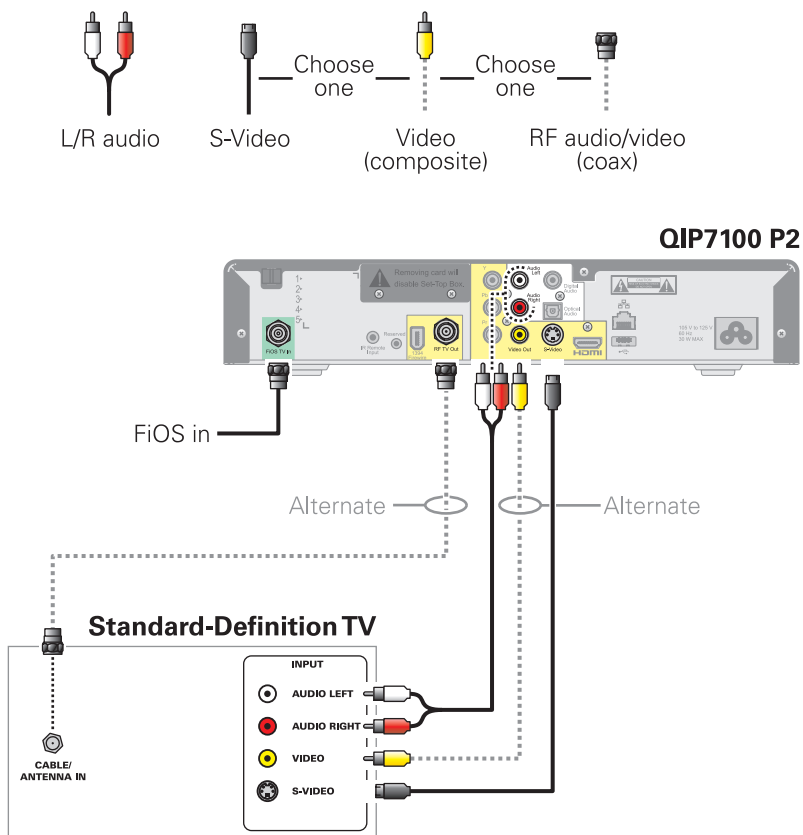



## Cabling to a Standard-Definition TV, A/V Receiver, and VCR

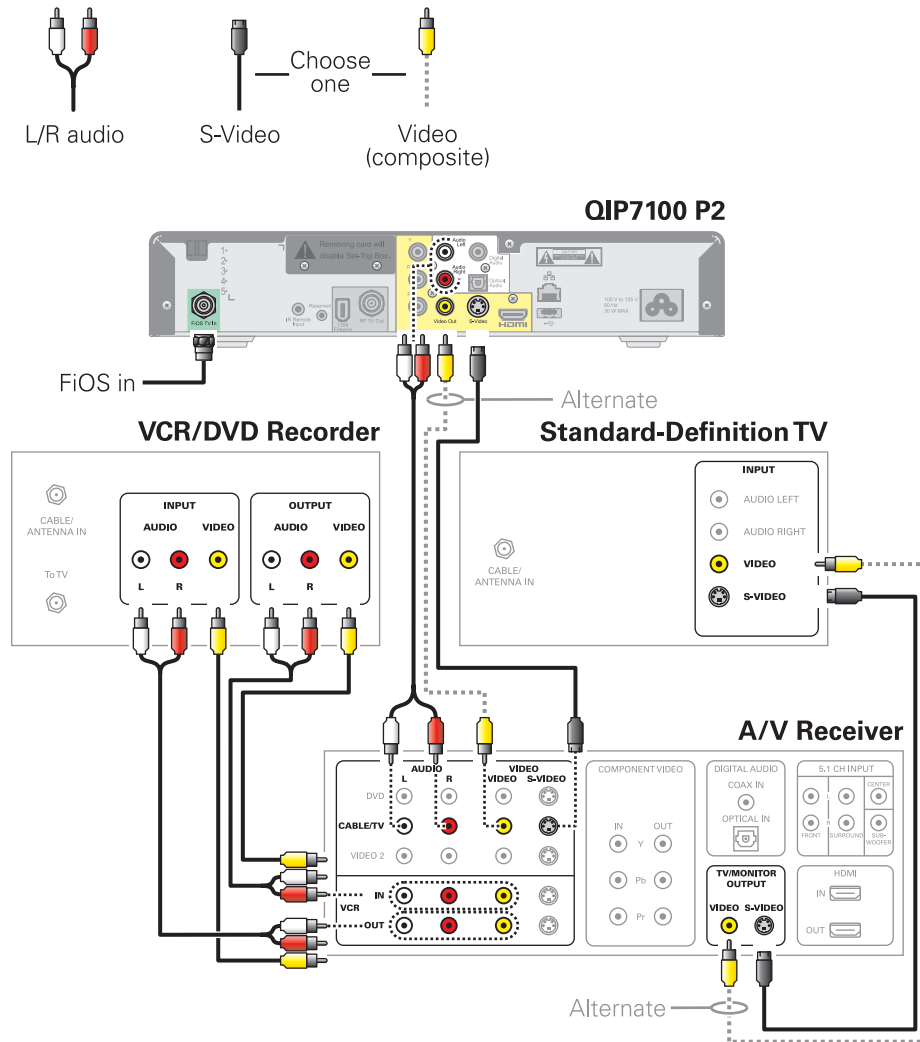

*Note: Because some entertainment equipment cannot simultaneously support composite video and S-Video, never simultaneously connect both video inputs.*

*Note: This connection method does not support HDTV. For information, see [Cabling to an HDTV for Video](#) in this section.*

## Troubleshooting

Troubleshooting guidelines follow. If problems still occur after performing the diagnostics, call your service provider for assistance.

Problem — If this occurs:	Solution — Then do one of the following:
<b>The QIP set-top will not power on</b>	<ul style="list-style-type: none"><li>• The QIP set-top may have received a software update and may not power on while the new software is being installed. Try again in a few minutes.</li><li>• Verify that the AC power cord is connected to the QIP set-top and an AC outlet. Unplug the QIP set-top from the AC outlet, plug it back in, and then press the POWER button.</li><li>• If the QIP set-top is connected to a switched outlet on another unit, verify that that unit is powered on. Unplug the power cord from the QIP set-top's AC outlet, plug it back in, and then press the POWER button. It is recommended that you use an unswitched outlet, if possible.</li><li>• Press the POWER button on the QIP set-top's front panel instead of the remote control. The batteries in the remote control may be depleted.</li></ul>
<b>The remote control does not work</b>	<ul style="list-style-type: none"><li>• Verify that the remote control is in "STB" mode.</li><li>• Verify that there are no obstructions between the remote control and the QIP set-top. Aim the remote control directly at the QIP set-top front panel, not the TV or VCR.</li><li>• The angle between the remote control and the QIP set-top may be too large. Stand in front of the QIP set-top and not too far to either side.</li><li>• Press and release operation keys one at a time, firmly and deliberately.</li><li>• Try changing channels using the buttons on the QIP set-top front panel.</li><li>• Check the batteries in the remote control. Install new batteries if needed.</li></ul>
<b>There is no audio when viewing cable channels</b>	<ul style="list-style-type: none"><li>• Verify that the mute button on the remote control has not been pressed. Press MUTE on the remote control to restore sound.</li><li>• If the QIP set-top audio output is connected to the TV, verify that the mute button on the TV has not been pressed.</li><li>• If the QIP set-top audio output is connected to a home theater receiver, verify that the receiver is set to the appropriate input source and the mute button on the receiver has not been pressed.</li><li>• Verify that you have the correct cables for the audio connections.</li><li>• Verify that the audio cables are firmly connected between the QIP set-top and the audio playback device (TV, receiver, DVD player, etc.).</li></ul>
<b>There is no audio from the center and/or surround speakers of a home theater receiver connected to the QIP set-top</b>	<ul style="list-style-type: none"><li>• Not all Dolby Digital programs feature full 5.1 surround sound. In some cases, the programs may only contain left and right stereo audio.</li><li>• Verify that the S/PDIF cable (coaxial or optical) is firmly connected to the QIP set-top and the home theater receiver.</li><li>• Verify that the home theater receiver is set to a surround sound audio mode (Dolby Digital, Dolby Pro Logic II, Dolby Pro Logic).</li><li>• Verify that the receiver is properly configured to work with all connected speakers.</li></ul>
<b>There is no video on the TV screen</b>	<ul style="list-style-type: none"><li>• Verify that the TV is powered on and set to the appropriate input source for the QIP set-top.</li><li>• Verify that the QIP set-top is powered on and tuned to an authorized cable channel.</li><li>• Verify that all video cables between the QIP set-top and the TV are firmly connected.</li><li>• Verify that the coaxial cable feed is firmly connected to the QIP set-top and the wall jack.</li><li>• If the QIP set-top video output is connected to a home theater unit, verify that the home theater unit is powered on and set to the appropriate input source.</li><li>• If the QIP set-top video output is connected to a TV through an HDMI connection, power off the TV and then power off the QIP set-top. Wait one second and then power on the devices.</li><li>• Not all HDTVs can display every output format (1080i, 720p, 480p, or 480i) available on the QIP set-top. To select a different format:<ol style="list-style-type: none"><li>1. Ensure that your QIP set-top is plugged into a power outlet and is turned off.</li><li>2. Ensure the TV is turned on and tuned to the appropriate channel for the set-top</li><li>3. Press the MENU key on the front panel. Your settings are displayed on the QIP set-top front panel display.</li><li>4. Use the ▲ and ▼ keys on the front panel to display the HDMI/YPbPr OUTPUT setting.</li><li>5. Press the ► key to cycle through the available output formats until a picture displays on the TV.</li></ol></li></ul>

Problem — If this occurs:	Solution — Then do one of the following:
<b>No graphics or program guides appear on the TV screen</b>	<p>If you use the IEEE-1394 connection, on-screen graphics, including closed captions and program guides, are not displayed by the QIP set-top. On-screen graphics and captions may still be overlaid by your TV, if enabled.</p> <p>Alternatively, use HDMI or component video instead.</p>
<b>No closed captions display</b>	<ul style="list-style-type: none"><li>• Verify on the User Settings menu that closed captions are enabled on the QIP set-top.</li><li>• Verify that closed captions are enabled on the TV.</li></ul> <p><i>Note: Closed captioning may not be available on the current program.</i></p>
<b>There are black bars to the right and left of the picture</b>	<ul style="list-style-type: none"><li>• Widescreen TVs display 4:3 programs in this format unless set to Stretch. Turn on the 4:3 OVERRIDE feature in the User Settings menu. This enables most widescreen TVs to stretch the video to fill the screen (see your TV manual for information about stretching 4:3 video).</li><li>• If the QIP set-top is connected to a widescreen TV, verify that the TV TYPE is set to 16:9 in the User Settings menu.</li><li>• Many HD programs are broadcast in pillar-box format with black bars to the left and right of the picture. These programs are broadcast in 16:9 HD formats, even though the video is not 16:9.</li></ul>
<b>There are black bars above and below the picture</b>	<p>All 4:3 HDTVs display HD programs in letterbox format (black bars above and below the picture) because of the shape of the display screen.</p> <ul style="list-style-type: none"><li>• Turn on the 4:3 OVERRIDE feature in the User Settings menu. This enables most standard screen TVs to display a full screen picture when the QIP set-top is tuned to a 4:3 program.</li><li>• Set the TV TYPE to 4:3 Pan-Scan. This enables the QIP set-top to remove the black bars above and below the picture when possible.</li></ul> <p>Some SD programs are broadcast in the letterbox format with black bars above and below the picture. Some widescreen TVs offer a zoom feature that may be able to remove the black bars (see your TV manual for information about zooming 4:3 video).</p>
<b>There are black bars on all four sides of the picture</b>	<p>This may occur on a 4:3 TV if the 4:3 OVERRIDE setting is OFF. To set 4:3 SD programming to fill the screen, depending on the capabilities of the TV, set 4:3 OVERRIDE to 480i or 480p.</p> <p>This may occur on a 16:9 TV if the active video for an SD broadcast is in letterbox format. To confirm, wait for a commercial or look for a graphic, such as a network logo. If the commercial fills the screen from top to bottom, or the graphic appears below the active video, the program is being letterboxed by the broadcaster. You can minimize this by activating the zoom feature on the TV.</p> <p>A broadcaster may include black bars on either side of a widescreen broadcast. This is called a “hybrid” aspect ratio and results in a black border surrounding the video on a 4:3 TV. Because this is part of the broadcast, the QIP set-top cannot correct the video. You may be able to minimize the border using the zoom feature on the TV.</p>
<b>Colors do not appear correctly</b>	<p>Be sure to match up each signal to the same YPbPr connection on the TV. Otherwise, colors will not appear correctly on your TV.</p>



© Motorola, Inc. 2009. All rights reserved.

[www.motorola.com](http://www.motorola.com)

MOTOROLA and the Stylized M Logo are registered in the U.S. Patent and Trademark Office. All other product or service names are the property of their registered owners. No part of the contents of this document may be reproduced or transmitted in any form or by any means without the written permission of the publisher.

548XXX-001-a 09/09